

# Laddomat® 10 Charging unit

## Installation instructions

### Connection

Laddomat 10 can be connected up as illustrated in the adjoining illustrations. When connecting several tanks, an even flow distribution can be achieved if each tank has the same overall pipe length to the charging circuit's connection points A–A. The radiator circuit is connected at B–B.

If connection is via B1 radiator heat takes priority over hot water.

Laddomat 10 can be assembled in any operating position. Please check for any air pockets and ensure that the inbuilt (turnable) non-return valve lip is positioned to provide a tight seal.

The overall pipe length should be as short and have as few bends as possible. You should ensure that all air pockets are eliminated.

The delivery pipe from the boiler should preferably be a no. R32 or should at least match the boiler's connection dimensions.

Refill is performed directly in the boiler, which means that in an emergency you can prevent the risk of boiling by simply adding cold water. In the initial fill-up, a hose is connected to run directly to the bottom of the tank.

### Aeration

For optimal aeration, the pipes should be structured to allow air to dispel itself to the expansion vessel.

You can also mount a purge valve with a high working capacity to speed up the aeration process.

### Electricity connection

The pump can be connected so that it is started either:

1. By the water thermostat when the boiler reaches a working temperature of approx. 75–85°C,
- or
2. When the flue and water thermostats are coupled in parallel.

The advantage with the flue thermostat is that the pump starts up quickly when you fire the boiler and stops quickly when the fire has gone out.

The water thermostat starts the pump when the residual heat raises the temperature in the boiler to over 90°C.

### Dimensioning

For boilers with outputs of up to 35 kW, the pipe dimensions of the circulation loop (*top of boiler: Laddomat 10, bottom of boiler: at least R25 or Cu 28*). Choose a circulation pump equivalent to Wilo RS 25-4 or Grundfos 25-40.

For longer lengths of pipe: a pump equivalent to Wilo RS 25-6 or Grundfos 25-60 should be used.

For boilers with outputs of 35–50 kW: a R32 or Cu 35 or larger should be used, as well as a Wilo RS 25-6 or Grundfos 25-60.

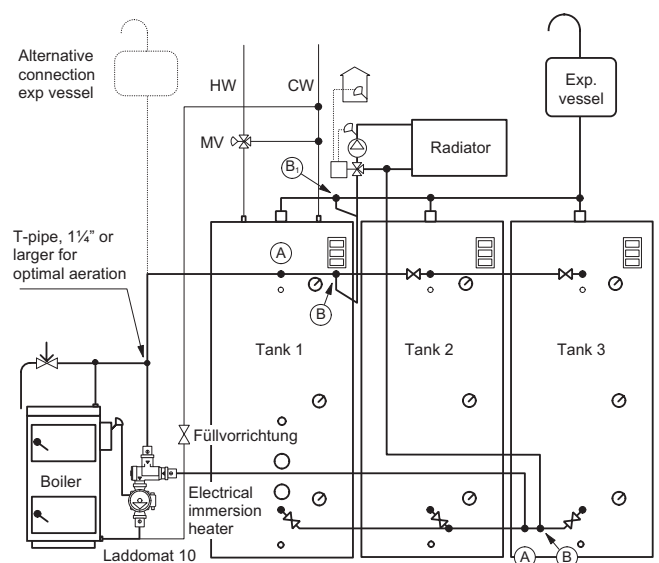
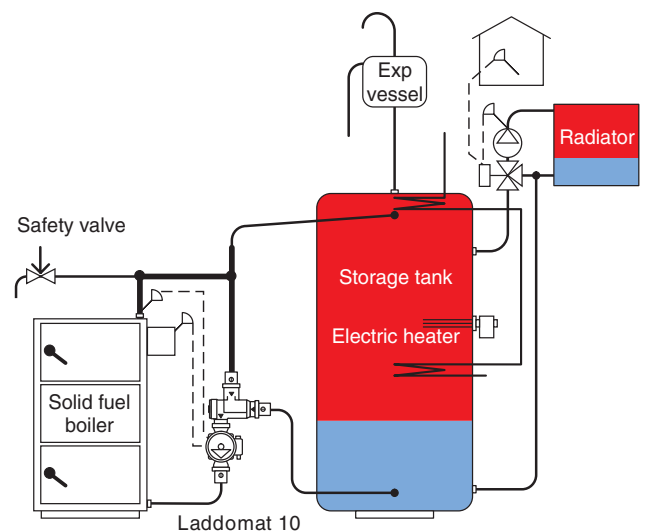

# Service

Servicing the Laddomat 10 is simplicity itself thanks to the union couplings and O-ring's robust seal.

Yearly inspections and cleaning reduces the risk of operating disruptions. Remove the plunger and non-return valve when inspecting, cleaning or changing the thermostat.

When reassembling, the O-rings and their sealing surfaces should always be lubricated with valve grease.

When reassembling, press the plunger down firmly towards the inside, until the seat ring touches the retaining edge, otherwise there is a risk that the valve will not seal the tank properly.

When the plunger measures 16.5 mm (as illustrated in fig. below) it is in the correct position.

Thermostat cartridges and O-rings are available as extra and should be changed every 5 years. You may also need to replace the cartridge more frequently if it is repeatedly exposed to high temperatures close to or above boiling point.

Also check the pump: dirt and deposits in the impeller can also reduce pump capacity significantly.

## Thermostat cartridges available as extra:

No.	Opening temperature
5840	55°C
8749	57°C
5839	63°C
8719	72°C
1456	78°C

## Checking the cartridge

The cartridge opens the plunger by approx. 8 mm when the temperature rises more than 9°C above opening temperature.

The plunger opens a further 2 mm at the next 5°C temperature increase.

When inspecting the cartridge, make sure it is working against the spring tension in the valve.

A damaged cartridge will always permit uncontrolled movement.

