

Charging unit for a solid fuel boiler with hot water heater  
and mixing valve, connected to a storage tank.

A thin boundary layer in the storage tank is necessary for an effective, easy-to-operate solid fuel boiler system.

It is vitally important for the boundary layer that the installation of the boiler and containers is correct.

Laddomat 4030 is a complete unit and is simple to install.

Laddomat 4030 ensures perfect charging.

## **Laddomat 4030 includes**

### **Valve assembly**

#### **Laddomat 4000 with**

- Charging and discharging valves with two check valves and a three-way thermal valve.  
Swedish patent No. 469 854.
- Charging pump
- Discharging pump
- Three ball valves

### **Electronic regulator**

#### **Laddomat 3000 with**

- An electronic control unit for additional heating
- Two temperature sensors
- An immersed sensor stick and clamping sleeve for the boiler sensor
- A clamp for the storage tank sensor

## **Technical data**

Maximum boiler output 35 kW

Pumps: Wilo RS25-60-130

Ball valves R25 (3 pcs)

Immersed sensor stick with

R10 connection, length 50–480 mm

Laddomat 3000:

See information sheet / Lm 3000



Laddomat 3000 increases the efficiency and the storage capacity of the tank.

Laddomat 4030 enables the boiler to attain the perfect working temperature in a very short space of time.

Prevents corrosion and thereby increases the lifetime of the boiler.

Laddomat 4030 charges the storage tank by means of a slow flow of hot water.

The vitally important boundary layer between hot and cold water is therefore optimal.

Suitable for boilers up to 35 kW.

The simple adjustment of Laddomat 3000 allows full control of charging and discharging.

Simple installation of water pipes and electricity.

Simple connection of additional alternative heat, making it is easy to use a tariff system.

## Charging the storage tank

Laddomat 4030 enables the boiler to attain the perfect working temperature in a very short space of time.

Charging pump  $P_L$  starts as soon as the temperature at the boiler sensor  $GT_p$  has reached  $80^\circ\text{C}$ . The Laddomat 4000-valve mixes the hot water from the top of the boiler with the colder water from the bottom of the tank to a temperature of  $60^\circ\text{C}$ . This water is heated as it enters the bottom of the boiler. There is no risk of condensation and corrosion at the bottom of the boiler because of the low temperature. Water at a temperature of  $85^\circ\text{C}$  is pumped very slowly into the top of the storage tank thereby maintaining the effective and important boundary layer in the tank. The hot water will not mix with the cold and heavier water below.

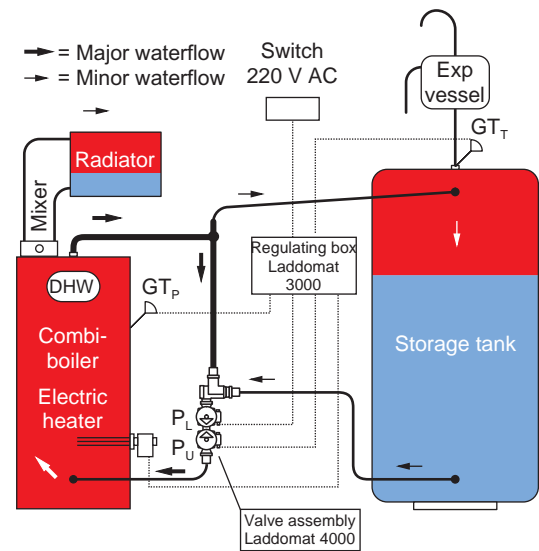

## Discharging the storage tank

When the fire stops and the boiler cools down, the sensor at the top stops the charging pump at a temperature of just below  $80^\circ\text{C}$ . When the boiler has reached the pre-set temperature of, for instance  $50^\circ\text{C}$  at the  $GT_p$  sensor, the discharging pump  $P_U$  starts. The cold water in the bottom of the boiler is transferred to the bottom of the storage tank and at the same time the hot water is transferred into the top of the boiler. This is done very slowly because of the restricting function of the Laddomat 4000 valve. The important boundary layer is thereby maintained in both the boiler and the storage tank.

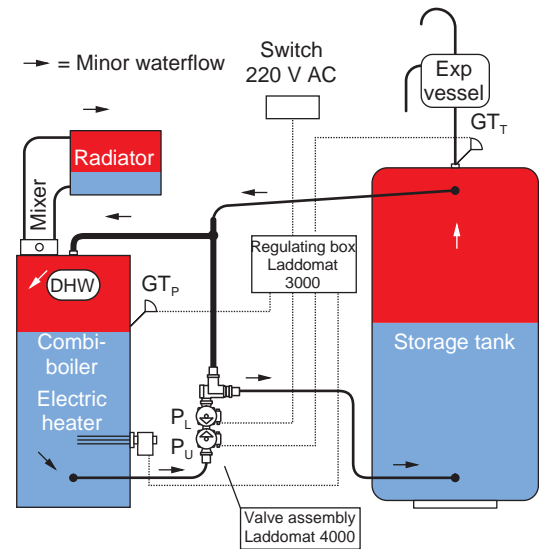

## Boundary layer

The *Boundary Layer* is a thin border between the hot water on top and the colder, denser water underneath.

The boundary layer keeps the bottom part of the boiler cold and there is therefore a minimum loss of heat through the convection part of the boiler. However, the top of the boiler, with the mixing valve and hot water heater, maintains the proper temperature.

The discharging pump operates for short intervals as the heat is used from the boiler. The hot water is kept in the well-insulated storage tank as long as possible, which increases the efficiency of the whole system.

## Additional heating

Discharge stops when the  $GT_T$  sensor at the top of the tank reaches, for instance,  $40^\circ\text{C}$ . The additional heating can now be started. Adjustment is done using the *Stop UL/Electrical Heating Start* knob. The  $GT_T$  sensor is located in the top connection pipe of the storage tank. The thermostat for additional heating is adjusted to, for instance,  $50^\circ\text{C}$ , which is sufficient for most domestic hot water and heating requirements.